

4-1) Two forces labeled F_1 and F_2 act on the same object. F_1 and F_2 have the same magnitude F , but are at right angles to each other. What is the magnitude of the net force (total force) acting on the object?

- A) F
- B) $2F$
- C) Between F and $2F$
- D) More than $2F$

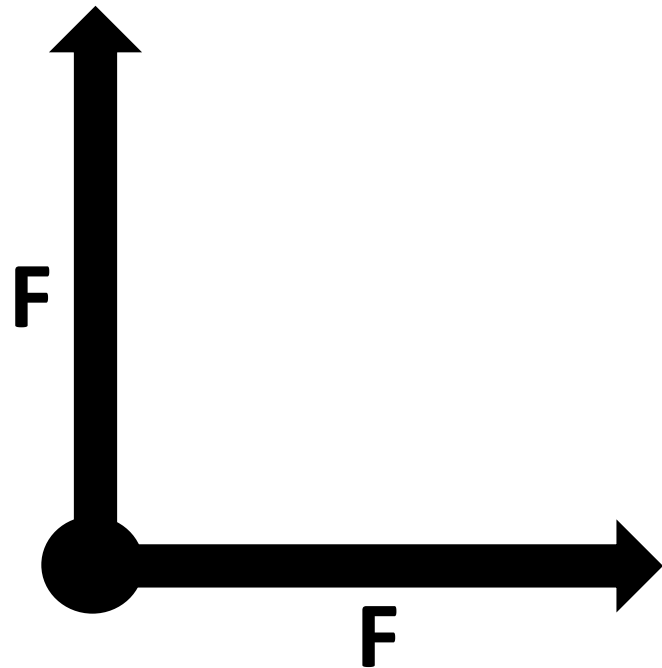

Reminders

- Fix your clicker issues by this Friday.

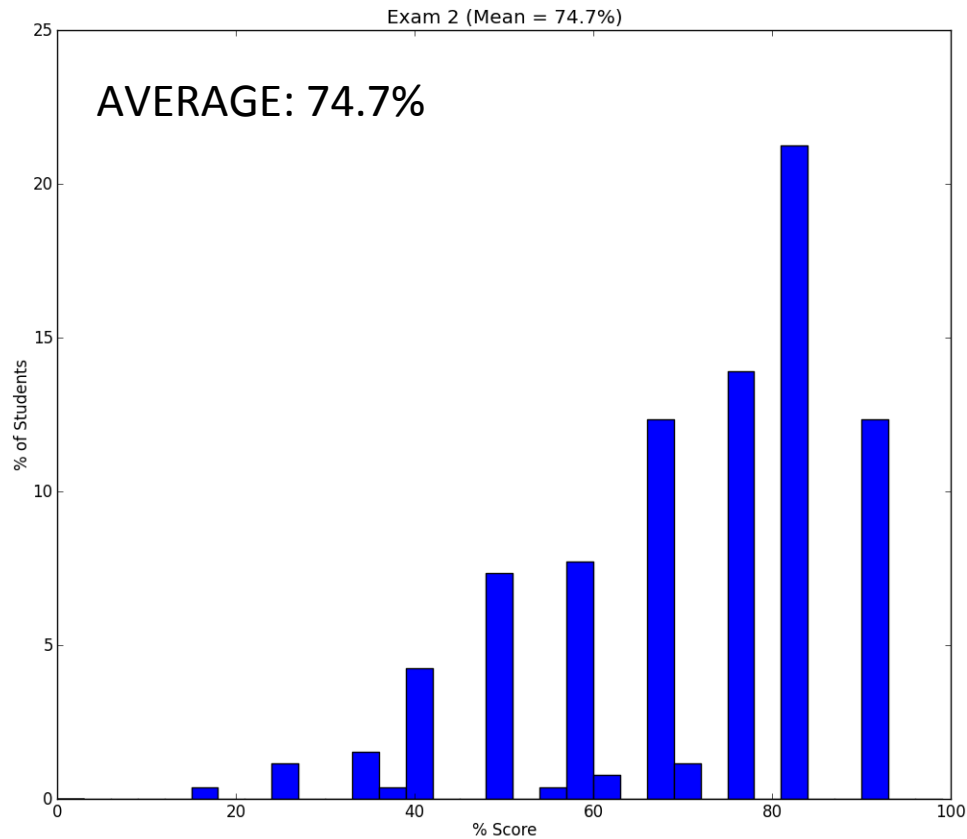

Newton's Laws

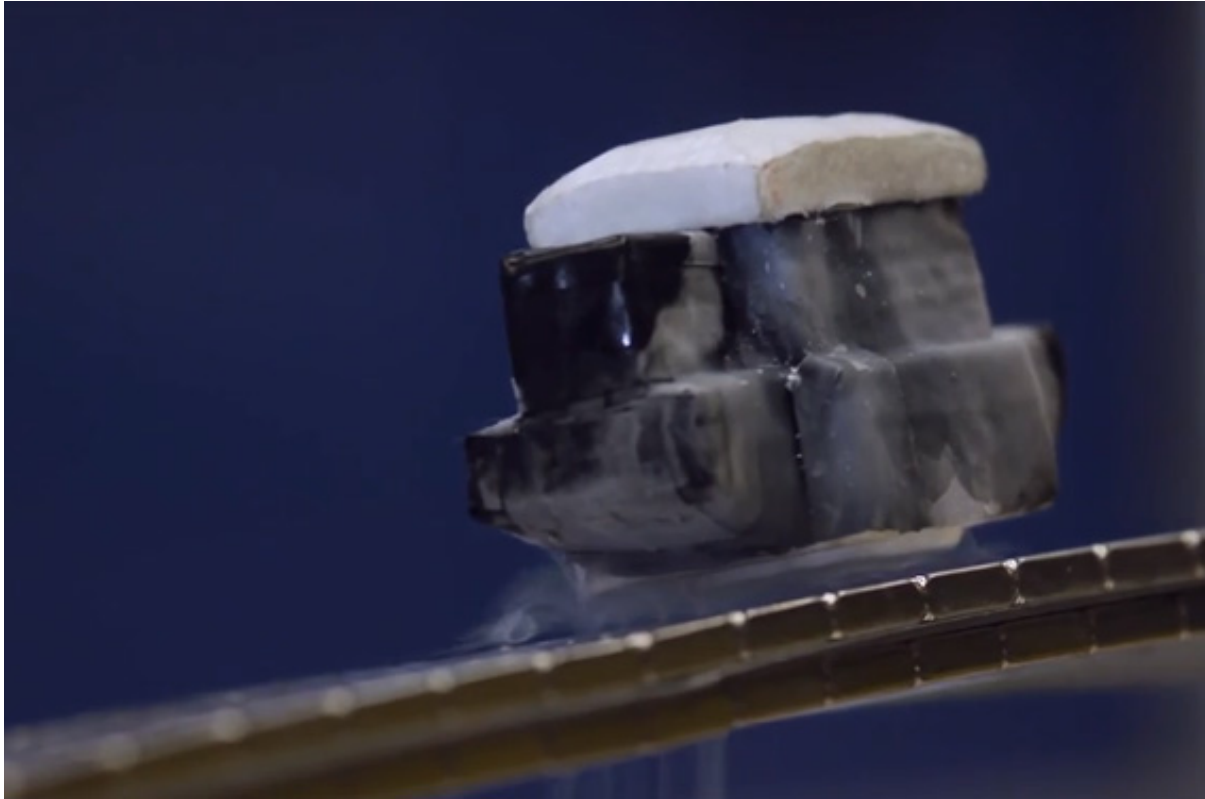

Superconductor on a Mobius Strip

<https://www.youtube.com/watch?v=zPqEEZa2Gis>

Isaac Newton (1642 – 1727)



1689 - Age 47



1702 - Age 60



1725 – Age 83

Average Life Expectancy 40-45

4-2) A glider is gliding along an air track at constant speed. There is no friction (Assume the air resistance is small enough to ignore). What can you say about the net force (total force) on the glider?

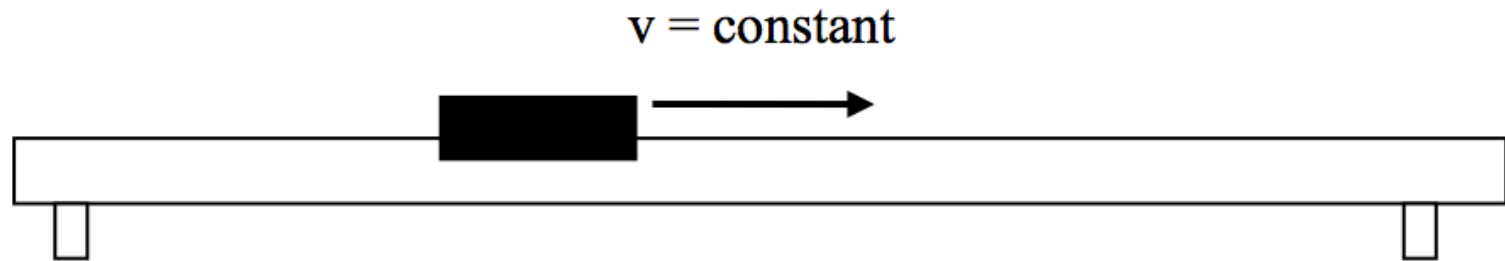

- A) The net force is zero.
- B) The net force is non-zero and is in the direction of motion.
- C) The net force is non-zero and is opposite the direction of motion.
- D) The net force is non-zero and is perpendicular to the motion.

4-3) An astronaut in intergalactic space is twirling a rock in space. Suddenly the string breaks when the rock is at the point shown.

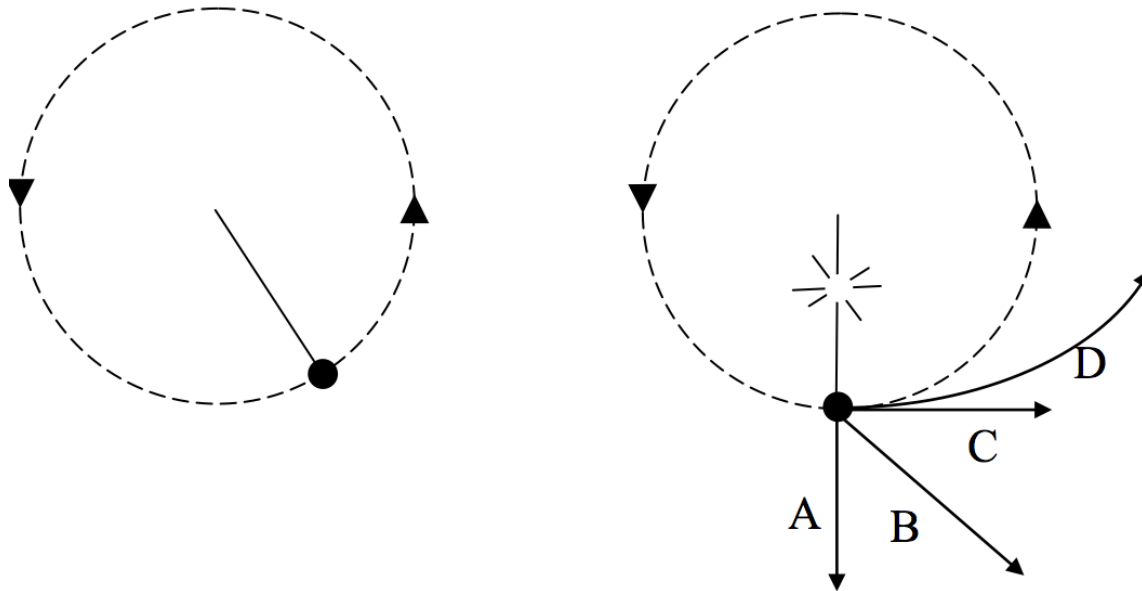

Which path (A, B, C, or D) does the rock follow after the string breaks?

4-4) An object is being lowered on a cord at a constant speed. Assume no air resistance. How does the magnitude of the tension T in the cord compare to the magnitude of the weight mg of the object?

- A) $T = mg$
- B) $T > mg$
- C) $T < mg$

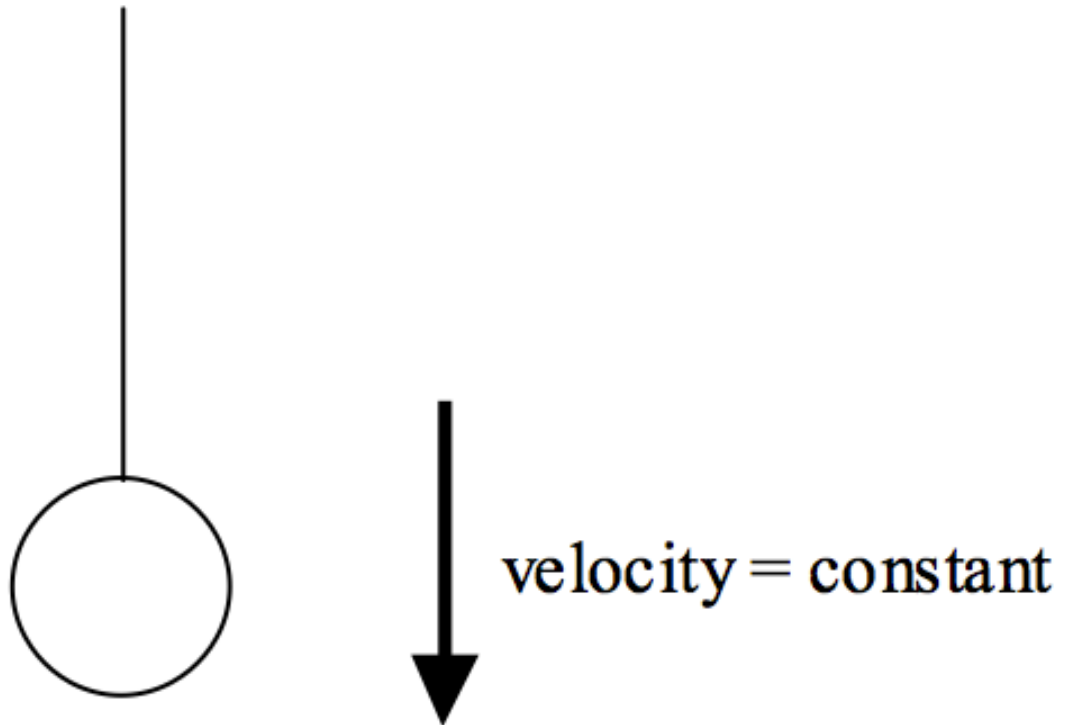

4-5a) An object is being lowered on a cord at a speed which is decreasing. There are only two forces on the object, the weight, magnitude mg , and the tension, magnitude T , in the cord. What is the direction of the acceleration?

- A) up
- B) down
- C) $a=0$

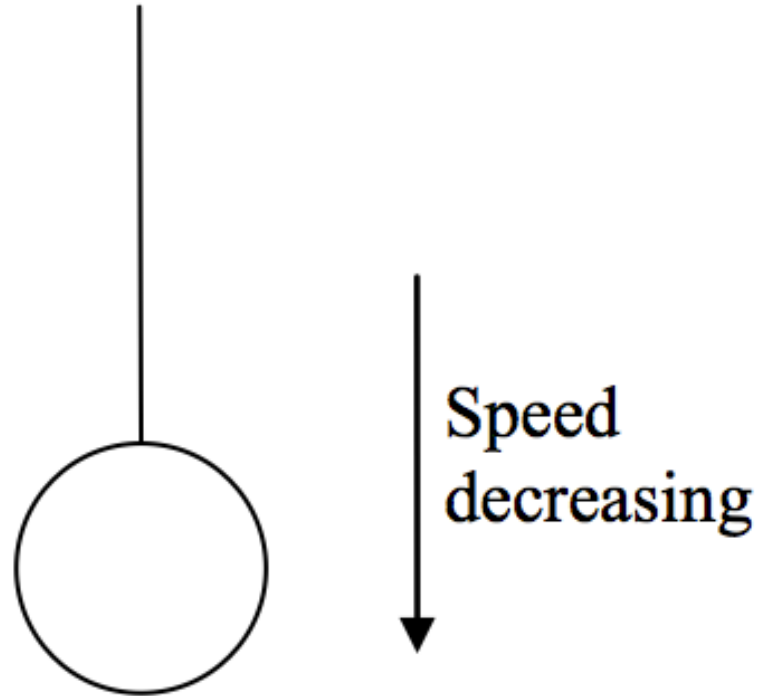

4-5b) An object is being lowered on a cord at a speed which is decreasing. There are only two forces on the object, the weight, magnitude mg , and the tension, magnitude T , in the cord. Which equation is true?

- A) $T = mg$
- B) $T > mg$
- C) $T < mg$

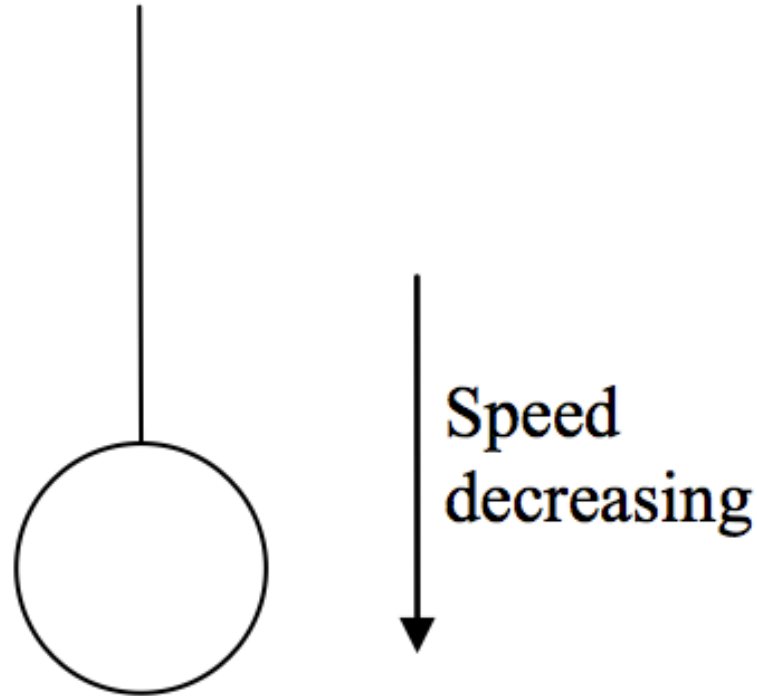

4-6a) A glider is on a tilted air track and is sliding downhill (NO FRICTION).

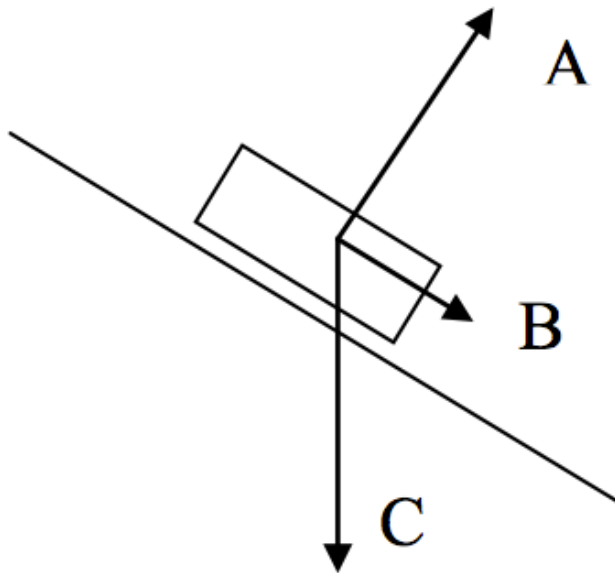
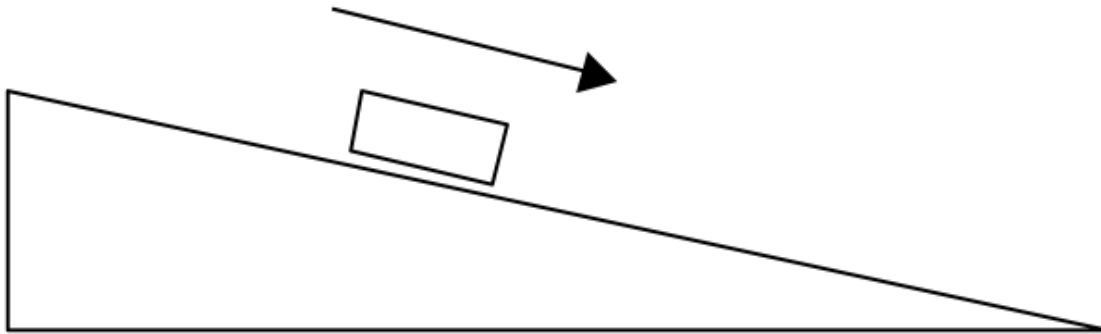

What is the direction of the net force on the glider?

D) None of these. Some other direction

4-6b) A glider is on a tilted air track and is sliding downhill (NO FRICTION).

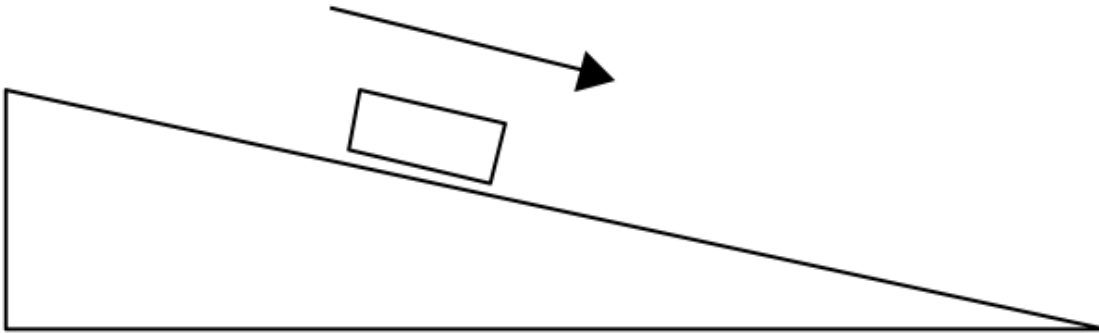

Would the answer be different if the glider was moving uphill because it had recently been pushed uphill?

- A) Yes, the net force would now be in a different direction than before.
- B) No, the net force would be the same as before.

4-7) A sailboat is being blown across the sea at a constant velocity. What is the direction of the net force on the boat?

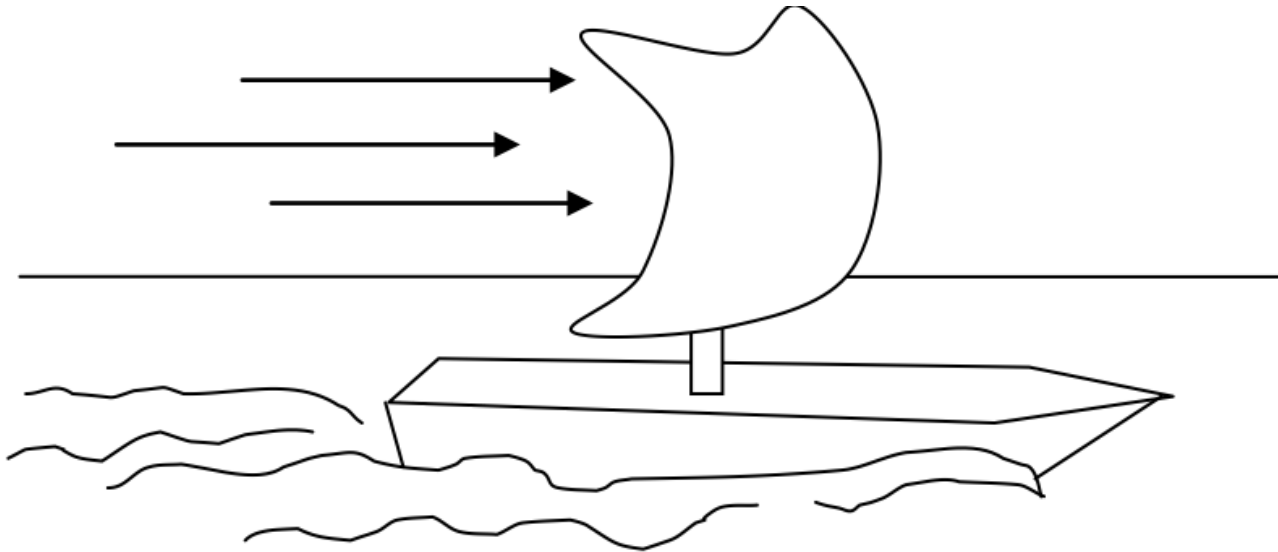

- A) Left B) Right C) Net force is zero
D) Down E) Up

4-8a) What is the correct equation?

- A) $T + mg = ma$
- B) $T - mg = ma$
- C) $T + mg = -ma$
- D) $T - mg = -ma$
- E) None of these

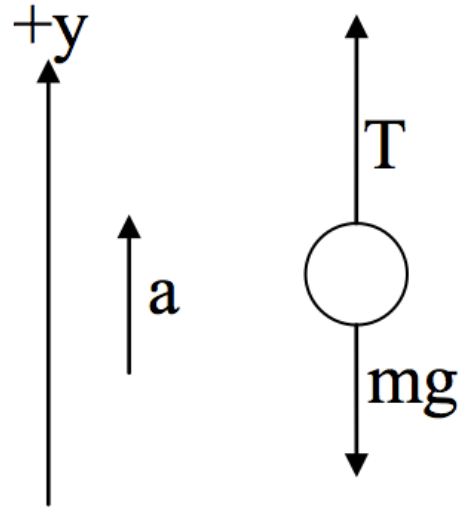

4-8b) A ball connected to a massless cord is pulled upward, but its speed is decreasing. Choose positive y to be in direction of the acceleration. Which is the correct equation?

- A) $T + mg = ma$
- B) $T - mg = ma$
- C) $T + mg = -ma$
- D) $T - mg = -ma$
- E) None of these

Reminders

- Fix your clicker issues by this Friday.
As of 9/17,
 - Unregistered Clicker 84B4D8E8
 - Unregistered Clicker 84B44979
 - Unregistered Clicker F67C5AD
 - Unregistered Clicker 92FA4F27

Weightless Cats

<https://www.youtube.com/watch?v=O9XtK6R1QAk>

4-9) A glider is on a tilted air track(NO FRICTION) and it is moving uphill because it was given a brief shove in the recent past.

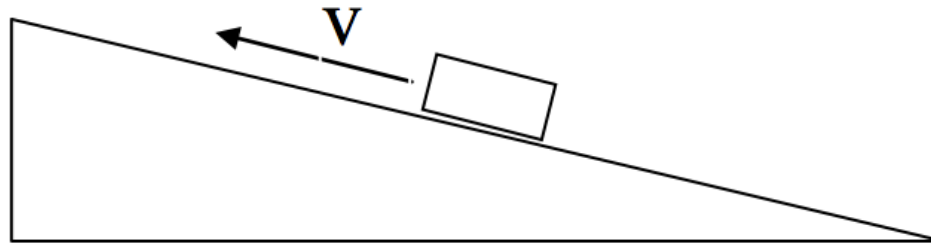

What is the direction of the acceleration?

E) None of these.

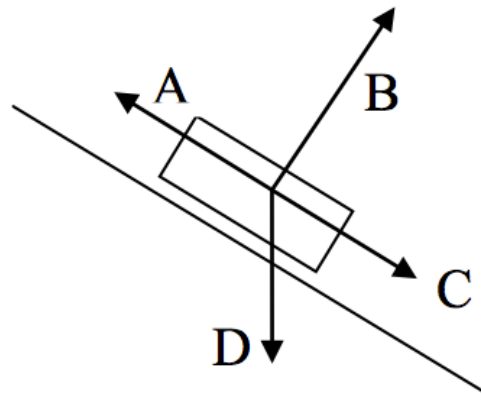

4-10) In a tilted x-y coordinate system, the acceleration is along the x-axis. The coordinates are tilted at an angle θ as shown. What are a_x and a_y , the x and y components of the vector \mathbf{a} ?

- A) $a_x = -a, \quad a_y = 0$
- B) $a_x = 0, \quad a_y = +a$
- C) $a_x = +a, \quad a_y = 0$
- D) $a_x = +a \sin\theta, \quad a_y = -a \cos\theta$
- E) $a_x = +a \cos\theta, \quad a_y = -a \sin\theta$

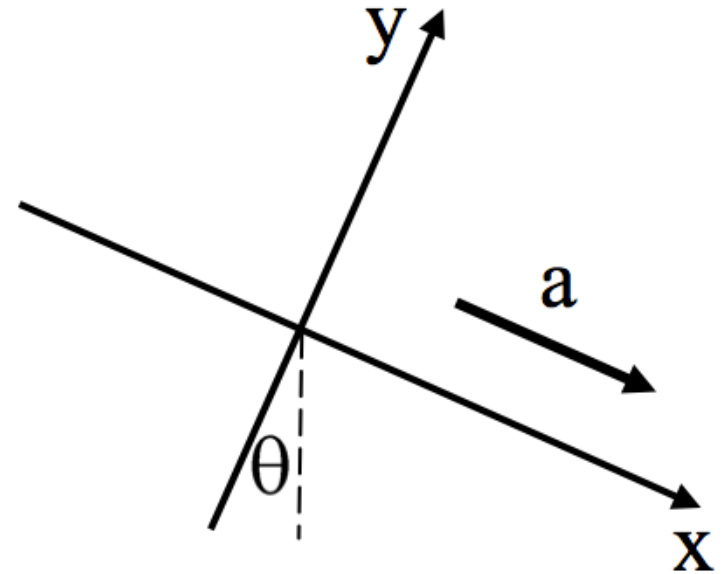

4-11) In a tilted x-y coordinate system, the weight vector mg is straight down. The coordinates are tilted at an angle θ as shown. What is W_y , the y-component of the weight mg ?

- A) $mg \sin\theta$
- B) $-mg \cos\theta$
- C) $-mg \sin\theta$
- D) $+mg$
- E) 0

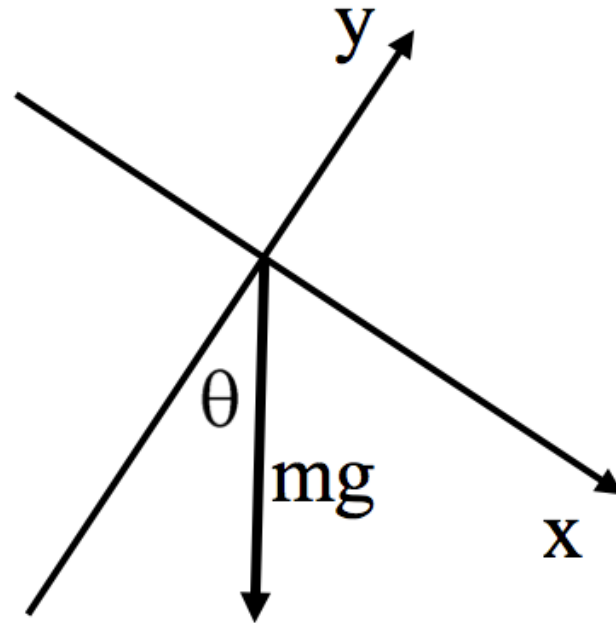

4-12a) Consider a person standing in an elevator that is moving upward at constant speed. Is the magnitude of the upward normal force, N , exerted by the elevator floor on the person's feet (larger than/same as/smaller than) the magnitude of the downward weight, W , of the person?

- A) $N > W$
- B) $N = W$
- C) $N < W$

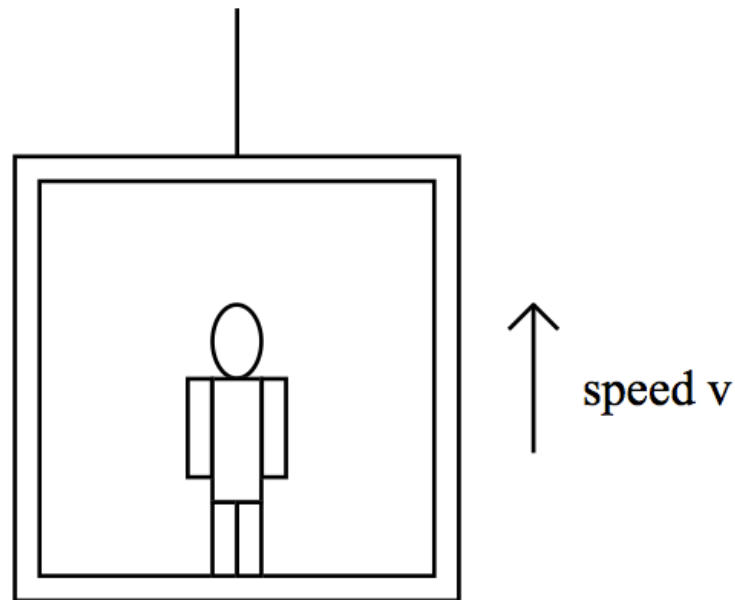

4-12b) Now suppose the elevator is accelerating upward. How does the normal force compare to the weight of the person then?

- A) $N > W$
- B) $N = W$
- C) $N < W$

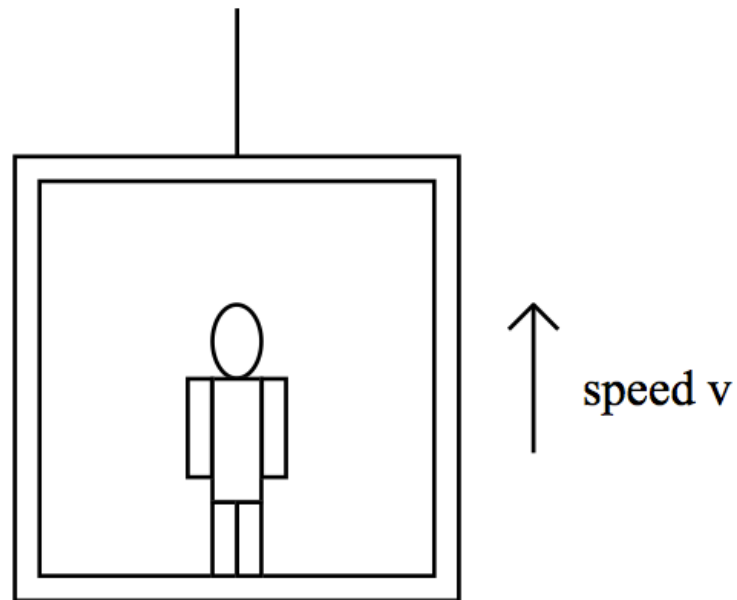

4-13) A moving van collides with a sports car in a high-speed head-on collision. Crash!

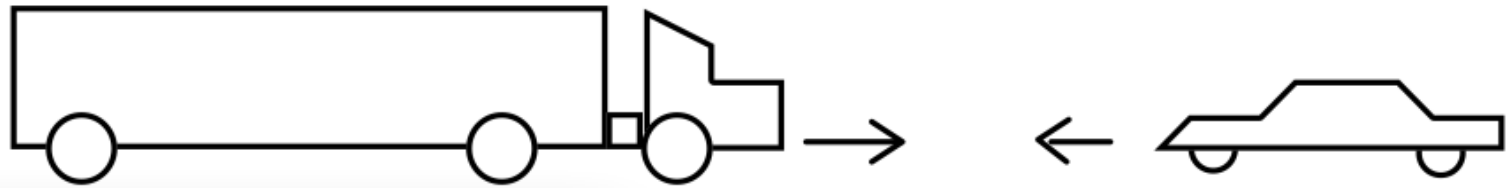

During the impact, the truck exerts a force F_{truck} on the car and the car exerts a force F_{car} on the truck. Which of the following statements about these forces is true?

A) The force exerted by the truck on the car is the same size as the force exerted by the car on the truck:

$F_{\text{truck}} = F_{\text{car}}$

B) $F_{\text{truck}} > F_{\text{car}}$

C) $F_{\text{truck}} < F_{\text{car}}$

4-14) A book sits on a table. Everything is at rest. The normal force from the table on the book is equal in magnitude to the weight of the book.

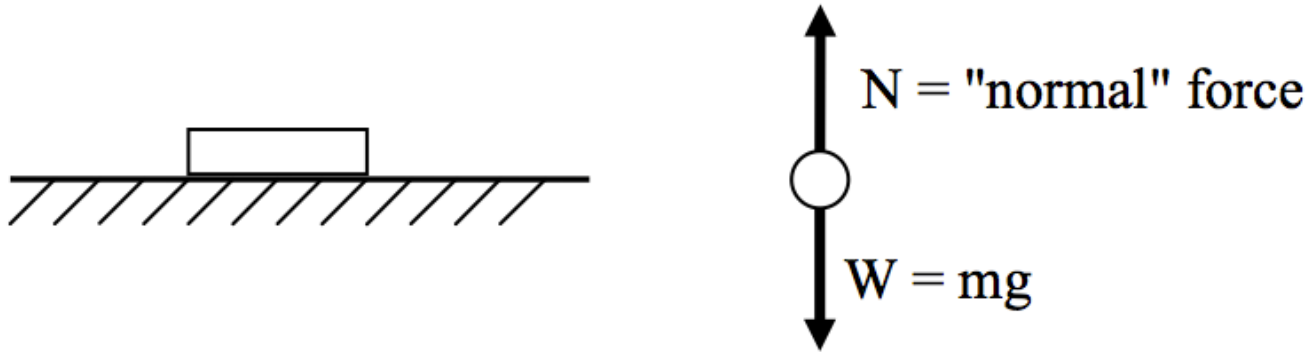

Are the normal force and the weight force members of an "action-reaction" pair from Newton's 3rd Law?

A) Yes B) No C) Impossible to answer

4-15a) Skinny and Fatty are having a tug-of-war. So far, no one is winning.



What is the direction of the force of friction from the floor on Skinny's feet F_s ?

- A) Right
- B) Left

4-15b) Skinny and Fatty are having a tug-of-war. So far, no one is winning.



How large is the force of friction on Skinny's feet $|\mathbf{F}_S|$ compared to the force of friction $|\mathbf{F}_F|$ on Fatty's feet?

- A) $F_S > F_F$ B) $F_S = F_F$ C) $F_S < F_F$

4-16) An Atwood's machine is a pulley with two masses connected by a string as shown. The mass of object A, m_A , is twice the mass of object B, m_B . The tension T in the string on the left, above mass A, is...

- A) $T = m_A g$
- B) $T = m_B g$
- C) Neither of these

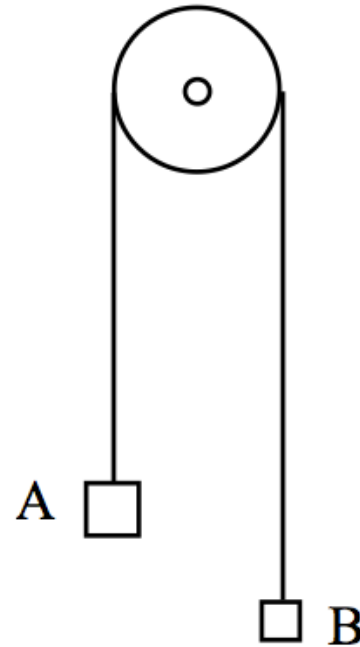

Reminders

- Fix your clicker issues today.
As of 9/17,
 - Unregistered Clicker 84B44979
 - Unregistered Clicker F67C5AD
 - Unregistered Clicker 92FA4F27
- LearnSmart will be pushed back to Sundays
 - DC recommendation: Finish by Tuesday

4-17) A 12kg two-year old is at the Lansing Science Museum. She decides to play with the pulley chair, which has 6 pulleys. With what force does she need to pull down with to accelerate upward at 1m/s/s ? ($g=10\text{m/s/s}$)

- A) 10 N
- B) 11 N
- C) 20 N
- D) 22 N
- E) Something else



4-18) A mass m is pulled along a frictionless table by a constant force external force F_{ext} at some angle above the horizontal. The magnitudes of the forces on the free-body diagram have not been drawn carefully, but the directions of the forces are correct.

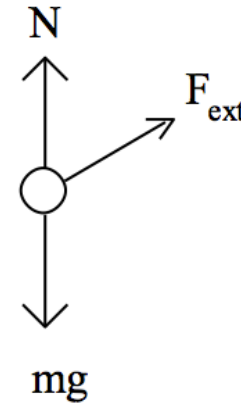
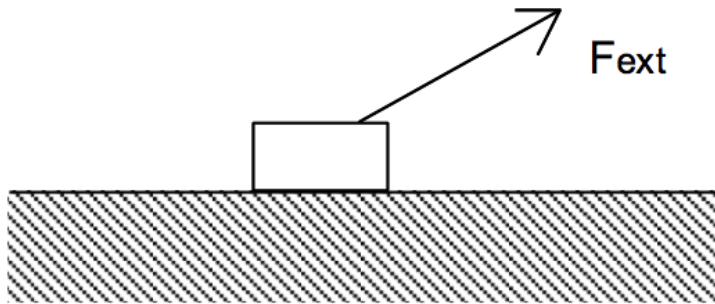

Which statement below must be true?

- A) $N < mg$ B) $N > mg$ C) $N = mg$

4-19a) A mass m is accelerates downward along a frictionless inclined plane. The magnitudes of the forces on the free-body diagram have not been drawn carefully, but the directions of the forces are correct.

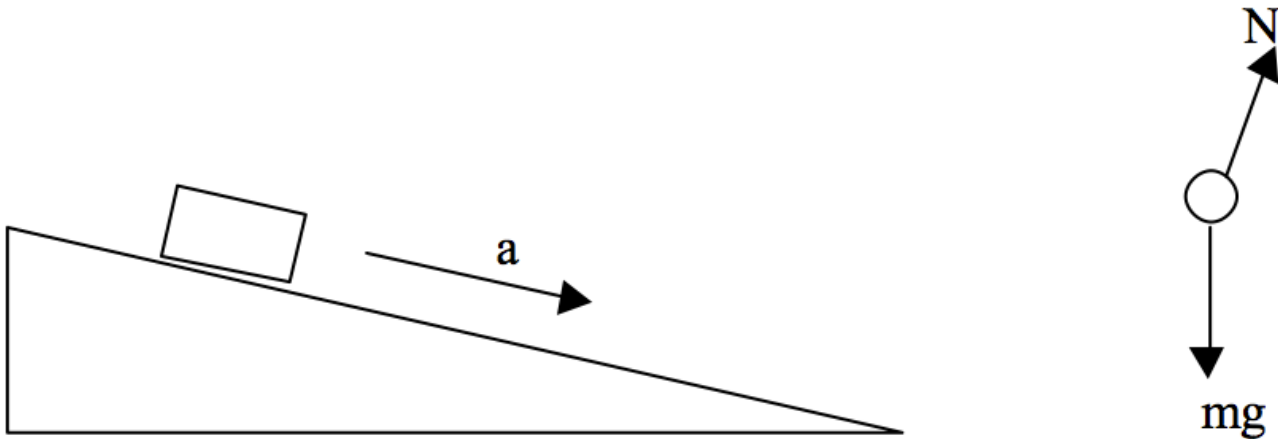

Which statement below must be true?

- A) $N < mg$ B) $N > mg$ C) $N = mg$

4-19b) A student chooses a tilted coordinate system as shown, and then proceeds to write down Newton's 2nd Law in the form $\Sigma F_x = ma_x$, $\Sigma F_y = ma_y$. What is the correct equation for the y-direction $\Sigma F_y = ma_y$?

- A) $N - mg \sin\theta = ma$
- B) $N - mg \cos\theta = ma$
- C) $mg \sin\theta = ma$
- D) $N - mg \cos\theta = 0$
- E) $N + mg = ma$

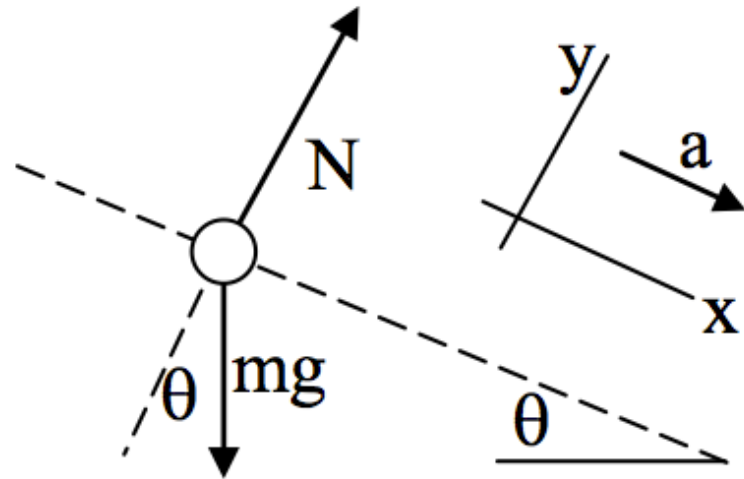

4-20a) A mass m is pulled along a rough table at constant velocity with an external force F_{ext} at some angle above the horizontal. The magnitudes of the forces on the free-body diagram have not been drawn carefully, but the directions of the forces are correct.

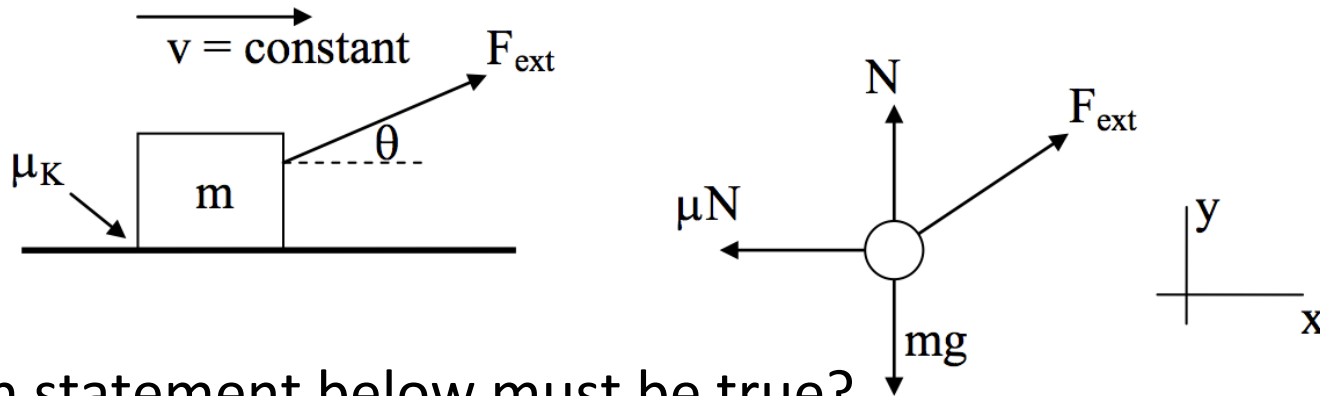

Which statement below must be true?

- A) $F_{\text{EXT}} > F_{\text{FRIC}}$, $N > mg$
- B) $F_{\text{EXT}} < F_{\text{FRIC}}$, $N < mg$
- C) $F_{\text{EXT}} > F_{\text{FRIC}}$, $N < mg$
- D) $F_{\text{EXT}} < F_{\text{FRIC}}$, $N > mg$
- E) None of these.

4-20b) A mass m is pulled along a rough table at constant velocity with an external force F_{ext} at some angle above the horizontal. The magnitudes of the forces on the free-body diagram have not been drawn carefully, but the directions of the forces are correct.

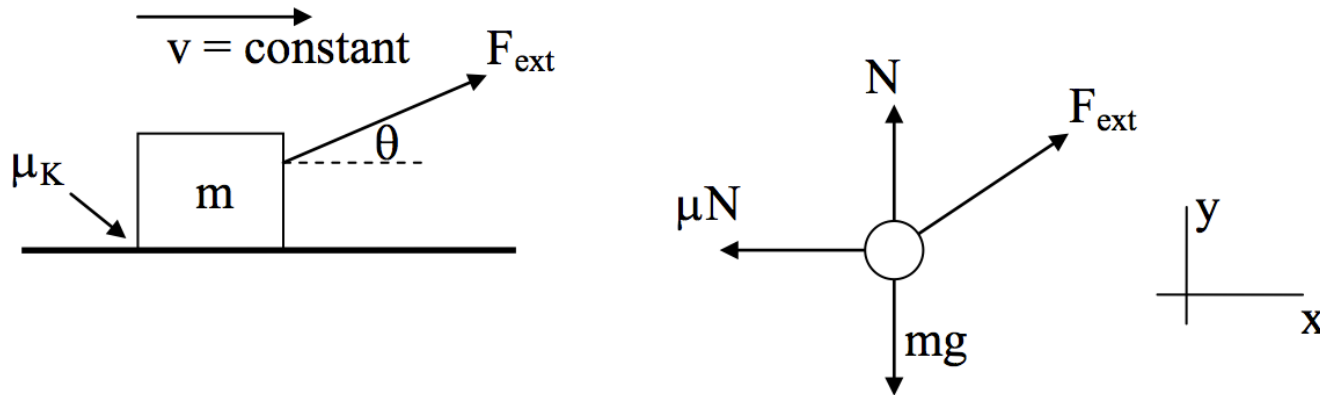

What is the correct y -equation (given the choice of axes shown) ?

A) $+N - mg \sin\theta = ma$

B) $+N - F_{\text{EXT}} \sin\theta - mg = 0$

C) $+N - mg + F_{\text{EXT}} \sin\theta = 0$

D) $+N - mg + F_{\text{EXT}} \cos\theta = 0$

4-21) A mass slides down a rough inclined plane with some non-zero acceleration a_1 . The same mass is shoved up the same incline with a large, brief initial push. As the mass moves up the incline, its acceleration is a_2 . How do a_1 and a_2 compare?

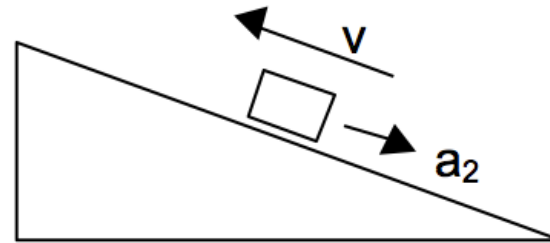
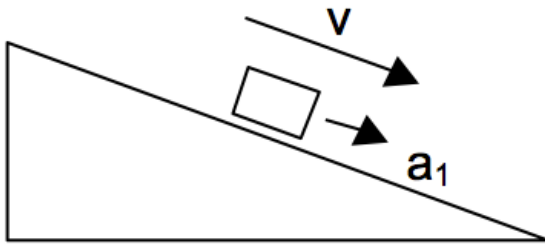

A) $a_1 > a_2$

B) $a_1 = a_2$

C) $a_1 < a_2$

Terminal Velocity

